

2. Constructive and design description of turnout.

In figure 1 is a pictures of a standard left-hand turnout 1435 gauge made from grooved rail Ri-59. It consists of: set of switches with flexible tongs 30m radius, manual sealed point setting mechanism with hydraulic damper, curved common crossing radius 20m, closure rails, tie rods, wood sleepers, and fastenings K-49 adapted to rail profile. These parts will be discussed separately below.

2.1. Set of switches

2.1.1. Description constructive

Switch set from Figure 2 consist of:

- Baseplate supports the entire mechanical construction of the switch. All the parts are assembled by welding. Base plate allows to fix switch to the sleepers or on to the continuous slab track. Fastening is made with bolts or coach screws.
- Stock rail made from grooved Ri60 rail has two roles: make link between rail in front of the turnout and straight closure rail situated after heel of them, and role of lateral support and protection for curved flexible tongue.

- Flexible tongue made from tongue profile UIC 49 can be moved to determine the direction for movement of traffic, straight or diverging. It provides support and guidance of the wheels on diverging direction. To reduce noise and increase the reliability was chosen flexible tongue design. Lateral movement of the tongue is achieved by elastic deformation.

- Support, wedge and bolts, provide fastening of heel tongue. Support is welded on base plate. The system permit to installing and removing the tongue without removing the road paving.

- Inserting rail made from grooved Ri60 rail has role to connect tongue hell with closure rail. Mechanical joint which are formed between the heel of tongue and inserting rail forming an angle of 45°, to ensure smooth passage of the wheel.

- Sliding plate supports the tongue and permit lateral movement of it. It is made from thick steel shit welded to web of stock rail and through 6 nervures to the base plate and rail foot. The plate is milled after welding to ensure vertical gauge and flatness

- Check rail has structural role and to allowing to embed the switch in pavement.

- Connecting tie rods are designed to ensure the correct gauge and allow

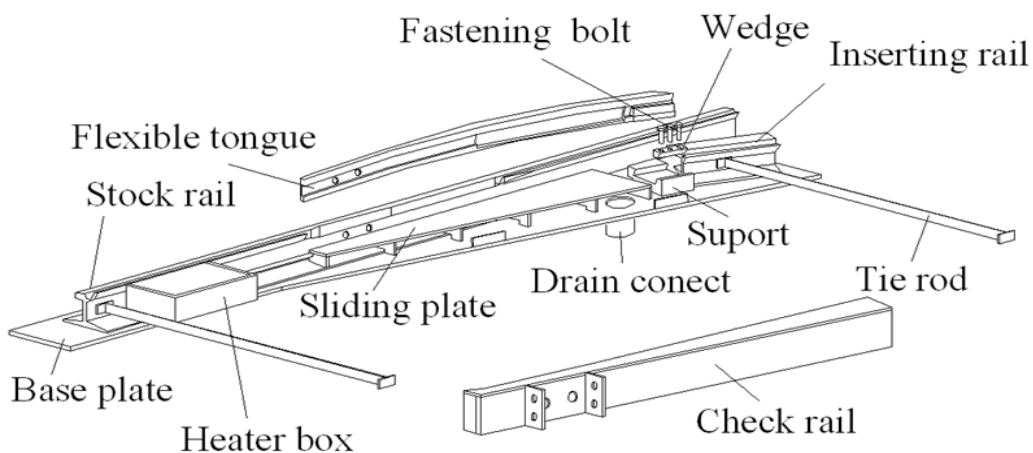

Fig. 2. Half set of switch [3]

assembly and disassembly for transport of both switches.

- Drainage connector is designed to connect the switch to the drainage system areas. It is very important to ensure proper drainage, especially in winter, when it can produce ice.

- Heating box is an optional feature and is intended to defrost switch in winter.

2.1.2. Design description

a. Rigid box-type construction do not allows large relative movement due to temperature variation between the tongue and the stock rail. Thermal expansion can only occur on tongue free portion between the heel and the tip. Variation lengths tongue due to the difference in temperature between -30°C and $+70^{\circ}\text{C}$. is ± 1.5 mm. being considered in designing the setting mechanism to avoid blocking operation.

b. To reduce operating force tongue has a weakened section over a length of 960 mm. after embedding. It was calculated that the driving force be less than 100 daN. The needle is stuck in the rails in free state. Driving rods passing through the two holes in the tip of the needle. Odds are designed for points machine H & K.

c. Hiding the tip of the tongue in stock rail is achieved by practicing a special form of milling in active edges of the stock rail. Moving to the tongue wheel running is done in the area where the tongue head width exceeding 20 mm (Fig. 3).

d. Straight tongue because of the way guiding bogie tram has two guide edges arranged one on each side to the tongue. Running edge disposed on the outer side face of the tongue must be crossed smoothly guiding the inner surface of the flange of the wheel, the tongue on the curved stock rail. For this purpose is made a milled recess to hide the side wall of the channel rail. The same milled recess is

provided on the curved tongue (Fig. 4).

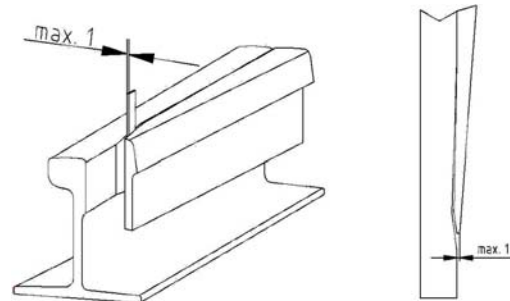

Fig.3. *Hiding of the tongue tip in stock rail*

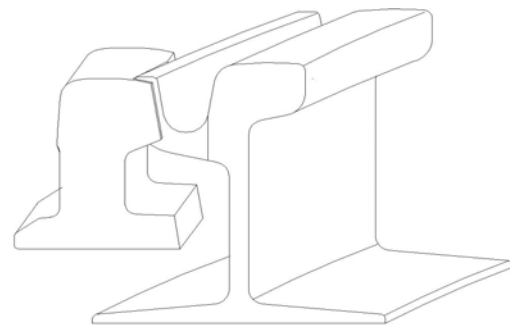

Fig. 4. *Milled recess to hide the side wall of the channel rail*

Figure 5 present milled recess to hide the side wall of the channel rail, made by company Mari Vila SRL., for switch R = 30m tram lines.



Fig. 5. *Milled recess made by company Mari Vila SRL*

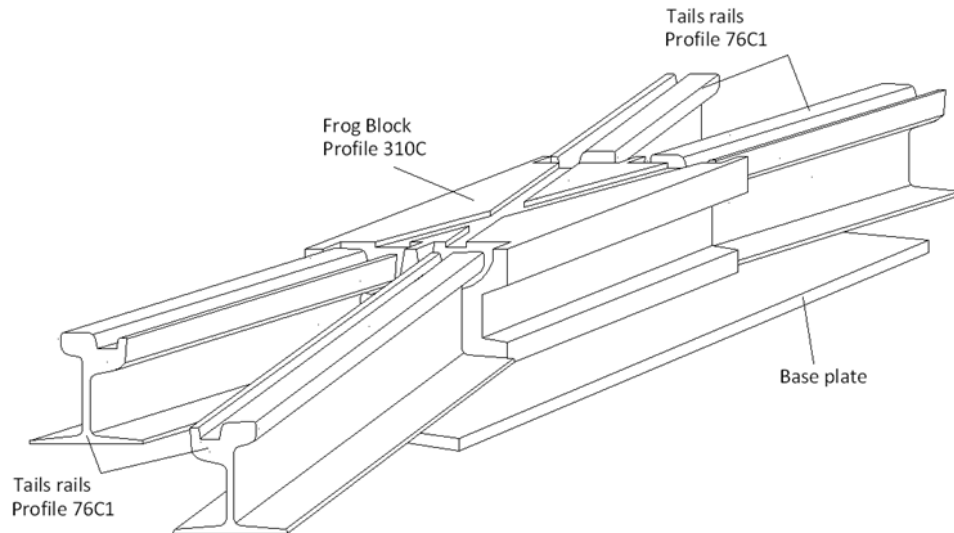

Fig.7. Simple frog [3]

b. Rail tails are made from special profile 76C1(Figure 9).

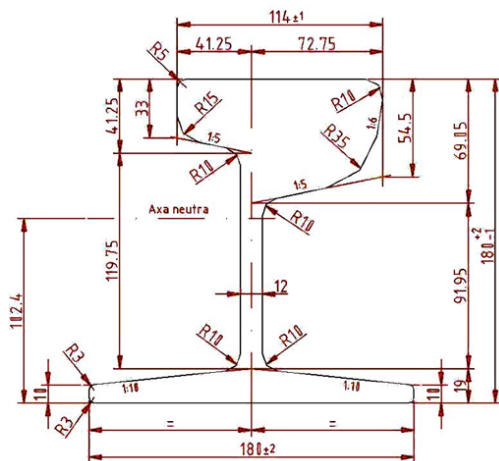

Fig.9. Grooved rail Profile 76C1

c. Base plate.

All the parts are assembled with weld on the base plate and welded joints between rails tails and frog block. Channels from rails and from frog are processed on CNC milling machine; after welding frog assembly (Fig.10). The variable channel depth is achieved by milling, no need

welding wedges plates. In figure is presented a machined frog ready for montage.



Fig.10. Tramway frog ready for montage

2.2.2. Particularities of tramway frogs.

For simple frogs with angles greater than 15° passing wheel loss vertical support on variable distance. When the angle is 90° the maximum distance is reached (width of rail channel). To reduce noise and the shock that occurs in these cases are now utilized wedge plates or rail channel with variable depth (Fig.6 Section AA). In the shallow channels wheels are supported on tip of wheels flanges (Figure 11).

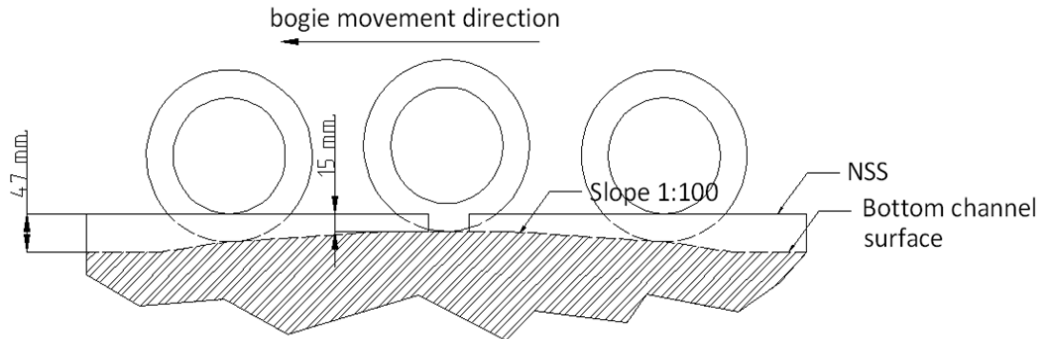

Fig.11. Wheel rolling on tip of the flange

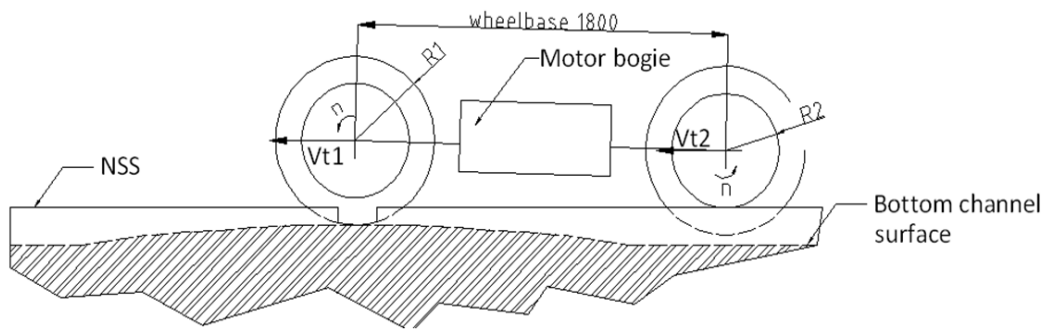

Fig.12. Dragging for motor axle in raised position

Running on flanges causes wear of flanges from tyres especially on motor bogies. Where appear the phenomenon of dragging for motor axle in the raised position (Figure 12).

With notations in the figure we can write:

$$V_{t1} = \frac{\pi \cdot n}{30} \cdot R_1 \quad (1)$$

$$V_{t2} = \frac{\pi \cdot n}{30} \cdot R_2 \quad (2)$$

The speeds of the two axles are not identical results that:

$$V_{t1} = V_{t2} \cdot \frac{R_1}{R_2} \quad (3)$$

The new tyre profile for urban transport is characterised by $R_1 = 364 \text{ mm}$ tire and $R_2 = 343 \text{ mm}$, respectively, and result:

$$V_{t1} = V_{t2} \cdot 1.061 \quad (4)$$

and for the axle dragging speed result:

$$V_d = V_{t1} - V_{t2} \quad (5)$$

For 50 km / h speed the result is:

$$V_d = (1.061 - 1) \cdot 50 \text{ km/h} = 3.05 \text{ km/h}$$

This move of dragging determines wear on the wheel flange and channels in frogs. The axles from carrier bogies rotate freely, because of this dragging do not occur. Appear transient phenomena due to sudden decrease of axis rotation that climbs the wedge plates.

Axis can move vertically with a speed of approx. 8.3 m / min for a bogie movement speed of 50 km / h. (I consider a slope of 1: 100 for ramps ascent - descent). It follows that when the tread of the first wheel comes in contact with the running surface of the rail normal collision speed is about 8.3 m / min.

Since rolling on the crown flange is disadvantageous must be avoided if

possible. In Figure 13 is shown how to determine the maximum angle between the cross channels where no longer needed low depths.

In the figure is shown a simple frog with both channels located in alignment with the crossing angle of 15° . It can be seen

that a bandage with RATB profile passing over do not loses vertical support due to the rail channel. In worst case, the width of vertical support of the tire is 25 mm (third position from left to right). Guidance is achieved by the other wheel of the wheelset (Figure 14).

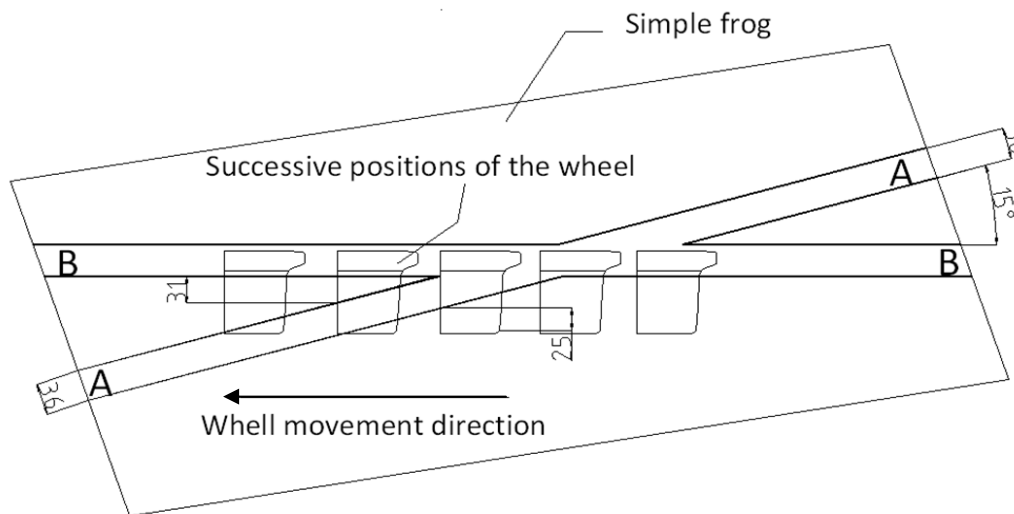

Fig.13. *Determination of the maximum crossing angles of passage that no needs shallow channels*

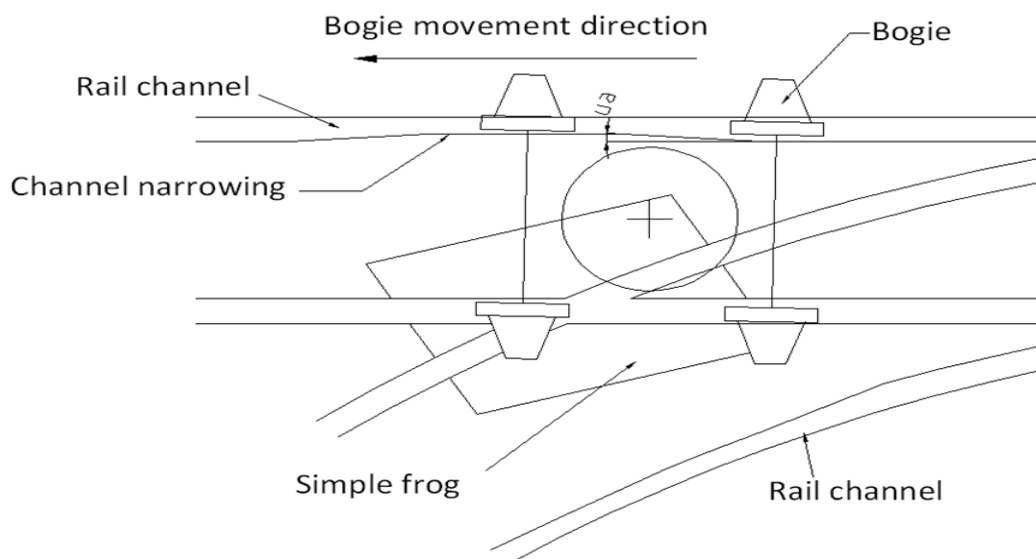

Fig.14. *Bogie guidance which passing over frog [1], [2]*

3. Geometry of the turnout

Turnout is indicated in two ways on drawings from Figure 15. The design drawing gives all the necessary details for the design and construction. The double line drawing with the two rails of a track drawn separately is shown in Figure 15.a. There is also sketch in which only centre line and tangent are shown. The mathematical point is indicated by small circle. The most important details of the turnout are indicated in Figure 15.b.

4. Conclusion

The high technicality of tramway turnouts demands top-level design and industrial skill.

The phenomenon of dragging presented above is complex and need to be carefully studied. Specialists from tramway design and track design must work together.

The singlemotor bogies with synchronous axles are aggressive with track. Need to be found other solution for bogies.

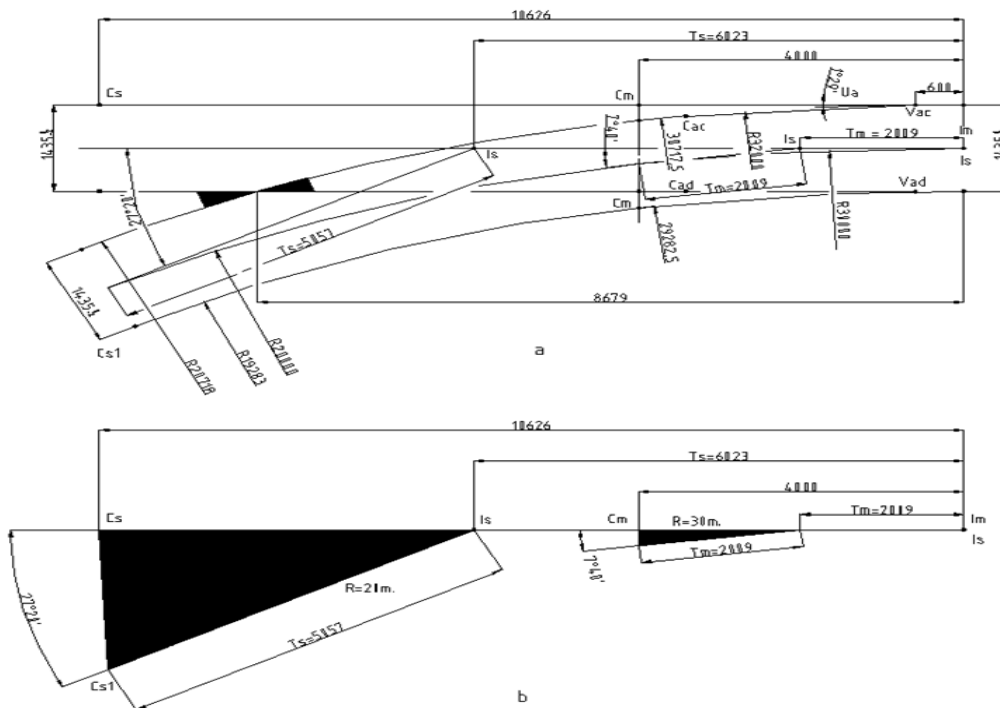

Fig.15. Geometry of turnout: a.double line drawing, b. sketch [3]

References

1. Bihoi, G.: Calea de rulare a tramvaielor, Ploieşti, 1998
2. Sadicov, O.N.: Tramvainii Putii
3. Stroistvo, Remont I Soderjanie, "Transport", Moskva, 1976
3. Zvenigorodski, S.: Simple tramway turnout. Project design, Bucharest, 2004