

EXTERNAL THERMAL INSULATION COMPOSITE SYSTEMS "ETICS"

C. CAZACU¹

Abstract:

The functionality and comfort of a building depend heavily on the thermal and phonic quality of the insulation, as well as the aesthetics of the facade. To achieve this, perfect compatibility between system components is required, as well as a correct design and execution.

Thermal insulation of buildings is a complex challenge, that require a profound and special analysis, and it is very important that the execution of buildings walls, guarantees constant levels of temperature and humidity, as well as lowest noise level, inside the building.

Key words: *thermo-insulating system, functionality, comfort, composite materials*

1. Introduction

In the case of a building project, 35% of the total energy consumed, it is on heating or cooling of the building, and up to one third of the generated heat, is lost due to the lack of thermal insulation of buildings.

Building materials and heat insulating systems tested and permanently optimized by manufacturers, allow the design of sustainable buildings, that over time, can significantly reduce energy consumption.

Behind every engineering act there is an idea, a design and a construction project. When a project is conceived, plans can become a reality by ensuring the processes run efficiently, construction sites are safe and reliable materials are used.

In constructions consumption resource are required for all operations. Starting with the construction materials we use, to the ability to facilitate responsible behaviour among employees, each element plays an important role on the impact that building has on the environment.

Discussing about the thermal insulation of a building, an old one or a new one, it is necessary to take into account several parameters, with a very important role, such as, [5]:

- functionality and time resistance;
- the thermal comfort, both in summer and winter, obtained by low energy consumption;
- mechanical resistances, both for structural elements and for closing elements;
- high fire resistance;
- final look, as pleasant as possible.

¹ Department of Civil Engineering, Faculty of Civil Engineering, University Transilvania of Braşov

Over time, various thermal insulation solutions have been tried for the exterior walls of buildings, either using building materials (BCA, BCU) with thermal insulation properties, or by insulating the walls with thermo-insulating materials, [5].

When we talking about external wall insulation systems and the associated top-coat renders, we commonly refer to them as ETICS, or external thermal insulation composite systems. This is essentially a technical description of what they are. ETICS conform to a set of globally recognised standards which take into account the methodologies and installation techniques commonly associated with the systems. These standards were historically developed in Europe, but have since spread out to all corners of the globe.

The present paper was developed in close cooperation with the ETICS - QETICS Thermal Insulation Quality System, based on a guideline, developed by ETICS [5], for the correct application of integrated thermo insulation systems (Figures 1 and 2), [5].



Fig. 1. *ETICS group logo* [5]



Fig. 2. *QETICS 2017 Guide* [5]

The establishment of this group aims to achieve several objectives such as:

- promotion of ETICS integrated thermal insulation systems, verified and tested at facade of new buildings and /or facade of old buildings, rehabilitated;
- promotion of training courses for quality assurance;
- setting minimum performance criteria for nZEB buildings;
- the establishment of a set of rules, for the operation, of these systems on the Romanian market, [5].

In QETICS-2017 guide, are presented important and interesting data about, [5]:

- description of integrated ETICS systems;
- the basic requirements that any of the materials from these system must complied to be a part of an integrated thermosystem;
- integrated system implementation technology and mandatory type details;
- rules and requirements to be observed by the designer, the contractor or the beneficiary of the thermal insulation work in the ETICS system.

The QETICS 2017 guideline includes data and recommendations that make the transition from the current European regulations ETAG 004 and ETAG 014 to the new EAD ETICS and EAD Anchors respectively, [5].

Also these guide can be traced to the idea of performing from the actual European standards SR EN 13499: 2004, SR EN 13500: 2004, to the new European standard (TC 88 project WI 00088330: 2016), in course of approval, [5].

We recommend, these material to be used as a set of rules, for application, promoted by QETICS, and it was developed as a result of the collaboration between the leading manufacturers of thermo insulating systems in Romania (Baumit, Caparol, Henkel, Knauf Insulation, Lasselsberger Knauf, Rockwool, Ejot) (ROMEPS, AAECR, APMCR, FPSC, Liga Habitat, Cluster Pro nZEB, UTCB, UAUIM, UPB), as well as the Technical Department of DGDR of MDRAPFE,[5].

2. The Overall Layout of the "ETICS"

An efficient thermo-system depends on two factors:

- first of all, the thermal insulation materials used,
- secondly, the type of the adhesive.

Each material has specific features and is recommended depending directly on the exterior climatic conditions to which it is exposed.

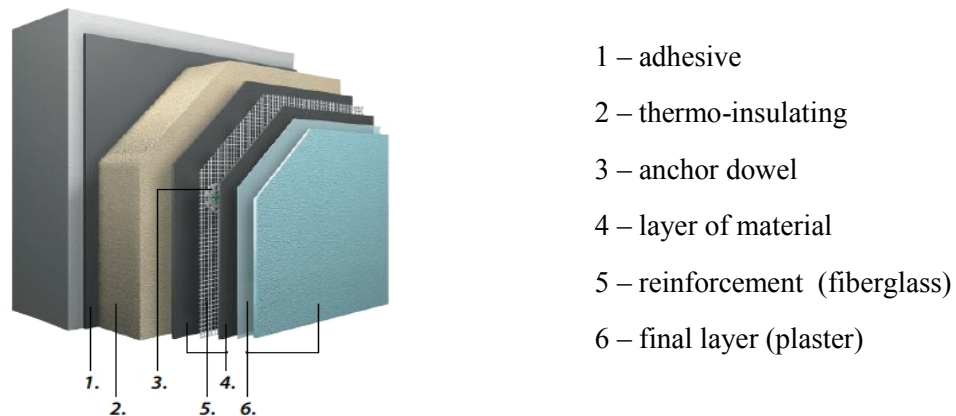

Fig. 3. *General ETICS system layers* [5]

2.1. The Support Layer

The support layer is the element over which the ETICS system sits. It can be mineral (concrete, brick masonry or backyard blocks), plastered or uncoated or wood. In new constructions, the underlay for the bonding of thermal insulation boards must be made in accordance with the technological standards in force.

However, it is very important that the applicator must verify its suitability to be an appropriate support. In old buildings, preparing and checking the support is of great importance for fixing the thermal insulation system.

Applying a plaster to the substrate, makes the support layer a "plastered substrate", which implies the need for fixing by gluing and docking. Preparing the support layer is especially necessary for old buildings that need rehabilitation. The usual support checks must be made on the entire surface (by sampling) before applying the thermal insulation system. And usually those are: the cleaning test, the scratch test, the wet test, the tear test, [3], [5].

2.2. Laying and Thermal Insulation Layer

It is good to note that mounting the system can only begin after, [4], [5]:

- the window and door frames have to be removed;
- all surfaces not covered (glass, wood, aluminum plywood, solances, pavements) must be covered with protective films;
- inner plasters and sapes must be finalized and dried;
- all horizontal surfaces (wall cornices, cornices) were covered with protective elements to prevent the infiltration of water behind the system thermo-insulating, during and after execution;
- all the windows and doors elements have been fitted, and also the elements that penetrate the system, such as pipes, supports, etc.;
- insulation penetrations must be designed and built in such a way as to ensure proper sealing;
- checking the presence of ascension moisture, salts, and their elimination, in the case of old buildings.

The *fixing layer* is an adhesive used for bonding the thermal insulation boards, which must be pre-added, dry mortar that adheres to all common types of construction materials, together with the insulating plates of the insulating panels.

The *thermo-insulating layer* can be made of expanded polystyrene, extruded polystyrene or mineral wool, as well as phenolic or polyurethane foam, which must complied all the performance requirements, provided by the actual standards.

Expanded polystyrene (EPS): recommended by the manufacturer, plates with dimensions (20 ÷ 200) x500x1000 mm, used as thermal insulating material in ETICS system. It must perform the minimum requirements according to the product standard SR EN 13163 + A1: 2015, as well as the quality provisions. Expanded polystyrene can be plain (white) or graphite (gray).

Mineral wool (MW): It is in the form of faced boards, treated or untreated with special products, with sizes (20 ÷ 200) x500 (600) x1000 mm or facade lamellas with dimensions (20 ÷ 200) x200x1000 1200) mm. It must meet the minimum requirements in accordance with product standard SR EN 13162 + A1: 2015.

Extruded polystyrene (XPS): can only be used on the sink area, spraying area and earth contact area.

Pure rigid polyurethane foam (PUR) sheets, according to SR EN 3165 + A1: 2015, or SR EN 13165 + A2:2016 or PF foam according to SR EN 13166 + A1: 2015, [1], [4].

2.3. Reinforcement Layer [5]

The reinforcement layer it is based on several elements, such as:

- adhesive mortar, pre-mixed (powdered or paste) and additivated;
- fiberglass mesh, which can be mounted in one layer, or in two layers (double reinforcement is only necessary in areas with high mechanical stress);
- additional elements of protection and stiffening of the reinforcement layer, using specials profiles, spacers, clips, etc., mounted in the fresh mortar.

2.4. Profiles and Decorative Elements[5]

Prefabricated decorative profiles are designed to replace the architectural accents of the facade, "classic" made of masonry or stucco.

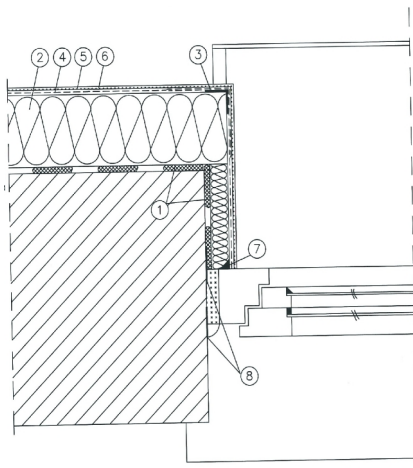

Fig. 5. *Detail model for joining with the side part of the window* [5]

- 1 – adhesive
- 2 – thermo-insulating
- 3 – corner profiles with glass fiber mesh
- 4 – army mesh with glass fiber
- 5 – primer
- 6 – final layer (plaster)
- 7 – acril
- 8 – seals

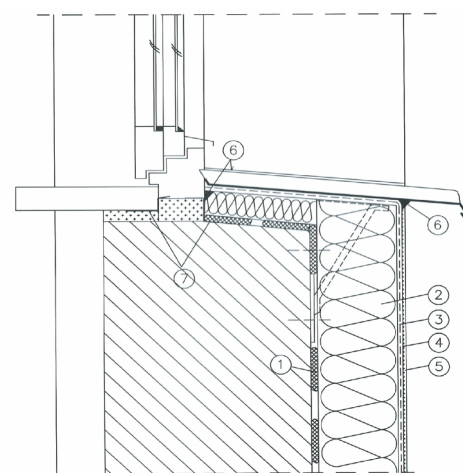

Fig. 6. *Detail model for joining with the bottom of the window* [5]

- 1 – adhesive
- 2 – thermo-insulating
- 3 – army mesh with glass fiber
- 4 – primer
- 5 – final layer (plaster)
- 6 – acril
- 7 – seals

These profiles are made of polystyrene, cut at certain size and shapes, delivery being supported by the manufacturer, covered with a protective layer, made of a mortar additivated mortar with a special resin, which ensures both the protection against atmospheric agents, and a good durability in operation.

The most common types of decorative facade profiles are: window frames, soldiers, cornices, vault keys, various ornamental figures, etc. The length of the profiles varies between 1.25 and 2.50 m for better handling and to avoid damage.

2.5. The Final Layer of Decorative Plaster

The main types of decorative plasters recommended by ETICS guide are, [4], [5]:

- acrylic resin acrylic plaster;
- silicate plaster based silicate resins;
- silicone resin silicone plaster;
- mixed resin based resins;
- white or colored mineral plasters.

The guide recommends that, prior to application of the decorative plaster, the substrate surface should be primed with the primer paint to the requirements of the manufacturer. The application of the finishing layer can be started only after a sufficient drying time for the reinforcement layer, and in favorable weather conditions. The application of the finishing material must be carried out in accordance with the manufacturer's application instructions.

Also, the drying time must be permanently observed and to be ensured the protection required, the thickness of the decorative plaster must be at least 1.5 mm. It is also possible to apply a second layer of plaster, made with small-grain plaster, in order to obtain a smoother surface appearance, [8], [9].

3. Quality of ETICS Systems

The concept of quality and constant performance for each component of this integrated system consists in observance of all procedures, technological records and related standards, which materialize through parameters and properties that remain constant throughout the existing period his.



Fig. 7. *Proper application of adhesive* [5]

4. Sustainability. Comfort and Health.

The construction area has a particular impact on the environment through his specific activities related to: design (lifetime design), production of building materials, transport and commissioning, exploitation and maintenance, demolition and recycling.

The impact, that today construction, have on the environment is mainly due to high energy consumption and significant CO₂ emissions - causing global warming and air pollution - due to the burning of fossil fuels, water pollution - due to the use of water for washing equipment, the production of solid waste - results from demolished concrete, noise and dust, caused by mixing of constituent materials. While the traditional approach is based on the principle of maximizing economic efficiency without taking into account the environmental impact, the new "sustainable construction" approach emphasizes the importance of reducing the impact of constructions on the environment, [2], [7]. It is recommended that all those involved in building projects (architects, engineers, investors) to establish a set of priorities addressing built objects, priorities that include objectives related to, [3], [6]:

- energy efficiency, a good selection of building materials such that environmental impact

is minimized;

- avoid using construction materials that contain toxic constituents;
- using organic methods on water consumption;
- ensure longevity and flexibility of construction;
- siting construction areas in places that would not involve deforestation or destruction of natural landscape.

In Romania, the energy intensity of the residential sector is eight times higher than in the European Union, due to the inefficiency of centralized heating and the lack of thermal insulation of most of the dwellings (apartments).

In the future, our country has proposed, by developing a national energy efficiency action plan, to achieve a reduction in greenhouse gas emissions in the residential sector by 41.5% (by 2020 compared to the average 2001-2005), [2].

The specific objectives that can contribute to the overall objective are:

- *improving the thermal performance of buildings*;
- encourage the development of projects targeting green houses, passive and / or active homes;
- modernization of the transport and distribution infrastructure of thermal energy in centralized systems;
- support program for improving *energy efficiency in buildings* occupied by people with low income;
- creating more green areas.

5. Conclusion

The lifecycle / functionality concept for a building is closely related to the energy consumption and materials used to build and exploit it, but also to the impact it has, among time, on the environment. A ecological building is designed to reduce the overall impact of the built-up environment on human health and the natural environment, through,[1]:

- the efficient use of energy, water and other resources;
- protecting occupant health and improving employee productivity;
- reducing waste, pollution and harm to the environment.

The present guide, QETICS, proposes a thermo-systems insulation that have the following advantages:

- improvement of the indoor microclimate and reduction of costs related to heating / cooling energy consumption (valid for buildings with complete thermal insulation system);
- improving the insulating capacity of the exterior walls;
- reduced labour costs;
- a wide variety of colours and / or textures;
- the possibility of making frames and using decorative profiles without causing damage or piercing by thermal insulation;

The QETICS Guide is an important step forward in moving from traditional to modern technologies and applying the principles underlying buildings with almost zero energy consumption, being a tool at the expense of designers and builders in assuring of

high performance tires of new or refurbished buildings, being also beneficial to the beneficiaries of the ETICS thermal insulation work. Also, the need for this guide is closely related to ensuring the quality of building insulation work, by improving technical regulations in this field and facilitating compliance with them, as well as by informing and training the internal construction market in order to increase the current level of technical knowledge and technologies used, before the legal requirements under Directive 2010/31/UE cause a blockage of the construction industry by the inability to build at the level imposed by the directive.

Acknowledgements

This paper was worked out in collaboration with the "*ETICS - QETICS Thermal Insulation Systems Quality Group*", which we would like to thank for all the support and documentation provided, specially Mr. Marius Furnica. We would like to say, that many of the information presented in this article, was taken over from the conference "The National ETICS Forum Bucharest, 21.09.2017" celebrating "55 years of thermal insulation of buildings in Romania", where, following the invitation from the QETICS group, our civil engineering department had the great pleasure to participate, in 21.09. 2017.

References

1. *Application Guide Lasselsberger-Knauf TERMOSistem 2007.*
2. *Catalog Baunit, Thermal Rehabilitation of Housing Blocks - MDR Brochure 201 Catalog Baunit 2016 – facades, plasters, digging.*
3. *Catalog Caparol 2016 - WDVS Atlas.*
4. *Guide EAE 2013: European Guideline for the Application of ETICS 2013.*
5. *Guide QETICS 2017: External thermal insulation composite systems "Etics" (Sisteme Termoizolante Compozite de fatada "ETICS"), 21.09.2017, <https://it.linkedin.com/company/eae---european-association-for-etics>*
6. *GP 123-2013, Guide on the design and execution of thermal rehabilitation works for dwelling blocks. O.M.D.R.A.P. no. 2.211 / 26.06.2013, M.Of., p. I, no. 538 bis/ 26.08.2013, B.C. no. 1/2013; (Ghid privind proiectarea si executarea lucrărilor de reabilitare termică a blocurilor de locuinte. O.M.D.R.A.P. nr. 2.211/ 26.06.2013, M.Of., p I, nr.538bis/26.08.2013, B.C. nr. 1/2013).*
7. *Henkel 2015 Catalog - Application Guide Ceresit Ceretherm.*
8. *Knauf Insulation Catalog - Details for Thermosystem CAD.*
9. *SC 007-2013, Framework solutions for the thermohigro-energy rehabilitation of existing building envelope tires (SC review 007-2002). O.M.D.R.A.P. No.280 / 05.07.2013, M.Of., p I, no. 540 bis / 27.08.2013, is abrogated SC 007-2002,(Solutii cadru privind reabilitarea termohigro-energetică a anvelopei clădirilor de locuit existente (revizuire SC 007-2002). O.M.D.R.A.P. nr.2.280/05.07.2013, M.Of.,p I,nr.540 bis/27.08.2013, se abrogă SC 007-2002).*